

Assembly note	
Pos.	Description
A1	OPTIONAL - Air pressure switch
A2	STANDARD pressure switch
A3	OPTIONAL - Oxygen purity controller
A4	OPTIONAL - Gas pressure transducer
A5	OPTIONAL - Flow meter transducer

Disegnato Designed by	R.C.	Data Date	16/01/06	Titolo Title
Controllato Checked by	-	Data Date	-/-/-	P.S.A. systems NS-Line P&I layout General arrangement
Approvato Approved by	-	Data Date	-/-/-	
Scala Scale	-/-			

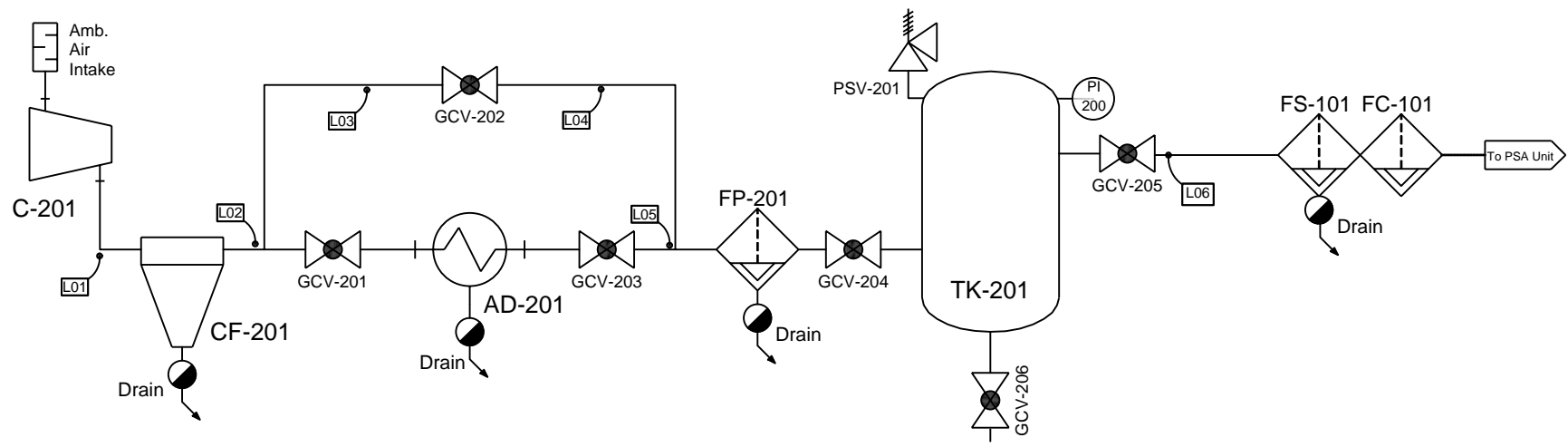

V. Giordana 48 - 58100 Grosseto - Italy - Tel. +390564458041 - Fax +390564458043
If present, design of all equipment of IGS ITALIA S.p.A. is not our asset (specifically the design of the equipment supplied by us).
This drawing is property of IGS ITALIA S.p.A. and it can not be reproduced or used without written permission of the owner.



Mod.	Air compressor	Cyclone filter		Air dryer		Particulate Filter		Air buffer	L01	L02	L03	L04	L05	L06

Disegnato Designed by	R.C.	Data Date	16/01/06
Controllato Checked by	—	Data Date	—/—/—
Approvato Approved by	—	Data Date	—/—/—
Scala Scale	—		

P.S.A. systems
NS-Line

P&I layout
General arrangement

